

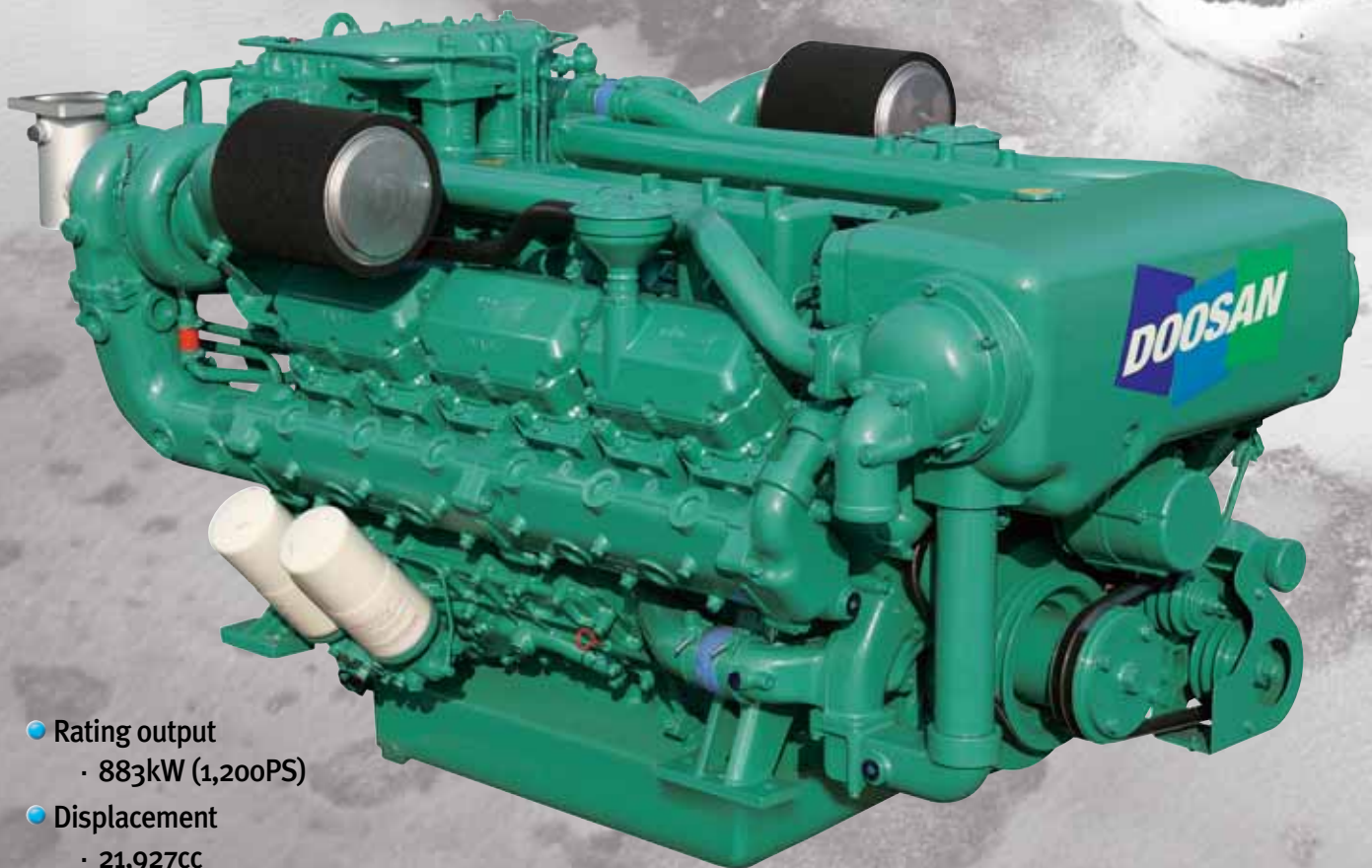

# Marine Diesel Engine 4V222TI

- Compact Design
- Excellent Performance
- Low Fuel Consumption
- Easy Maintenance



- Rating output
  - 883kW (1,200PS)
- Displacement
  - 21,927cc
- Dimension (L × W × H)
  - 1,874 × 1,243 × 1,548mm
  - Without Reduction Gear

**Doosan Infracore  
Engine**

## Main Specification

Model	Units	4V222TI		
		4V222TIH	4V222TIM	4V222TIL
Engine type		4 valve, 4 cycle, V type direct-injection, water cooled with turbo charger & inter-cooler		
Rating output	PS(kW) / rpm	588(800)/1,800	647(880)/2,100	883(1,200)/2,300
Displacement	c c	21,927		
Cylinder number - bore x stroke	mm	12 - $\phi$ 128 x 142		
Flywheel housing & fly wheel		SAE 1 & 14		
Low idling rpm	rpm	725 $\pm$ 25		
No load max. rpm	rpm	below 2,070	below 2,415	below 2,645
Compression ratio		14.3 : 1		
Firing order		1 - 12 - 5 - 8 - 3 - 10 - 6 - 7 - 2 - 11 - 4 - 9		
Governor type of injection pump		Mechanical variable speed (R.Q.V)		
Fuel consumption(only Ref.)@ rated power	g / PS.h	147	150	164
	Lit / h	143	160	239
Starting system		Electric Starting by starter motor		
Starter motor capacity	V - kW	24 - 6.6		
Alternator capacity	V - A	24 - 55		
Battery	V - Ah	24 - 200		
Cooling system		Indirect sea water cooling with heat exchanger		
Cooling water capacity	Max. / Min.	lit 103 / 92		
Fresh water pump type		Centrifugal type, driven by belt		
Sea water pump type		Bronze impeller type driven by belt		
Lubricating oil(Engine)	Pan capacity	lit	Max : 40, Min : 33 (Engine total : 43)	
	Pressure	kg/cm <sup>2</sup>	Full : 3.5, Idle : 1.2	
Direction of revolution	Crankshaf	Counter clockwise viewed from stern side		
Engine Size(L x W x H)	Without M/G	mm	1,874 x 1,243 x 1,548	
Engine dry weight	Without M/G	kg	1,920	1,960

H : Heavy Duty, M : Medium Duty, L : Light Duty

## Engine Dimension

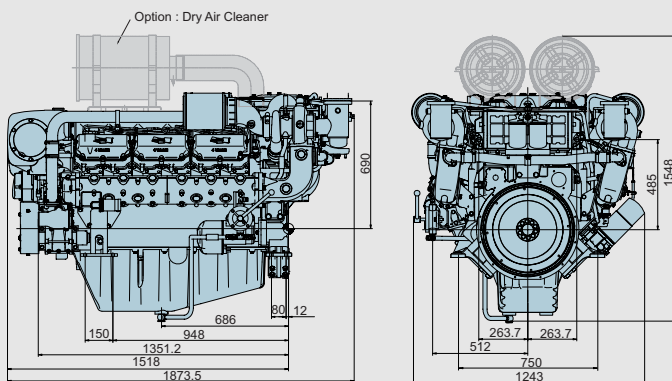

## Performance Curve

- Heavy duty : 588kW(800PS)@1,800rpm
- Medium duty : 641kW(880PS)@2,100rpm
- Light duty : 883kW(1,200PS)@2,300rpm

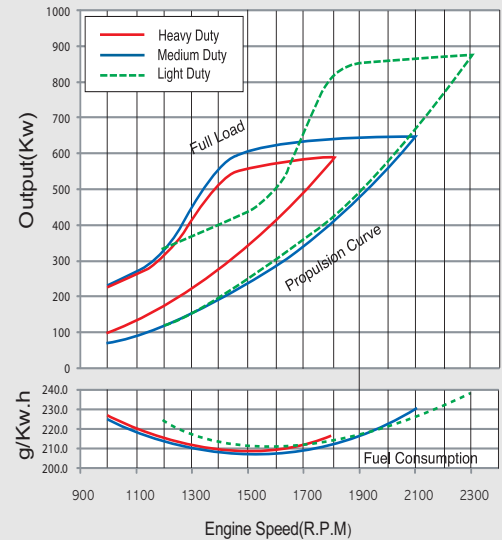

### Marine rating to ISO 3046

#### (1) Heavy Duty

Operation hours are unlimited per year, at average load is up to 90 %, at full load is up to 80 %  
 Typical gearbox ratio: 2.5 ~ 6  
 (Fishing trawler, Tug boat, Pushing vessel, Cargo boat, Freighter, Ferry)

#### (2) Medium Duty

Operation hours are up to 3,000 per year, at average load is up to 70 %  
 At full load is (up to 30 % / 4hrs per 12 hour operation period)  
 Typical gearbox ratio: 2 ~ 3.5  
 (Fishing trawler, Pilot boat, Escort boat, Passenger boat, Freighter, Ferry, Cruising vessel)

#### (3) Light Duty

Operation hours are up to 1,000 per year, at average load is up to 50 %  
 At full load is (up to 20 % / 2hrs per 12 hour operation period)  
 Typical gearbox ratio: 1 ~ 2.5  
 (Light weight fishing boat, Yacht, Cruising vessel, Fast boat, Fire pump)

(Nov.2012)

AUTHORIZED DEALER

## Doosan Infracore Engine

21/F, Doosan Tower, 18-12, Euljiro 6-ga,  
 Jung-gu, Seoul, 100-730, Korea.  
 Tel : 82 2 3398 8400  
 Fax : 82 2 3398 8509  
 Email : doosanmarine@doosan.com  
 http://engine.doosaninfracore.co.kr

\* Specifications are subject to change without prior notice.