



Marine Diesel Engine V222TI

- Compact Design
- Excellent Performance
- Low Fuel Consumption
- Easy Maintenance



- Rating output
 - 736kW (1,000PS)
- Displacement
 - 21,927cc
- Dimension (L × W × H)
 - 1,973 × 1,233 × 1,606mm
 - Without Reduction Gear

**Doosan Infracore
Engine**

Main Specification

Model	Units	V222TI (D2842LB)		
		V222TIH	V222TIM	V222TIL
Engine type		4cycle, V type, direct-injection, water cooled with turbo charger & inter-cooler		
Rating output	PS(kW) / rpm	720(530)/1,800	800(588)/2,100	1,000(736)/2,300
Displacement	c c	21,927		
Cylinder number - bore x stroke	mm	12 - 128 x 142		
Flywheel housing & fly wheel		SAE 1 & 14		
Low idling rpm	rpm	725 ± 25		
No load max. rpm	rpm	below 2,070	below 2,415	below 2,645
Compression ratio		15 : 1		14.6 : 1
Firing order		1 - 12 - 5 - 8 - 3 - 10 - 6 - 7 - 2 - 11 - 4 - 9		
Governor type of injection pump		Mechanical variable speed (R.Q.V)		
Fuel consumption(only Ref.)@ rated power	g / PS.h	148	154	159
	Lit / h	129	148	191
Starting system		Electric Starting by starter motor		
Starter motor capacity	V - kW	24 - 6.6		
Alternator capacity	V - A	24 - 50		
Battery	V - Ah	24 - 200		
Cooling system		Indirect sea water cooling with heat exchanger		
Cooling water capacity	Max. / Min.	lit 98 / 87		
Fresh water pump type		Centrifugal type, driven by belt		
Sea water pump type		Bronze impeller type driven by belt		
Lubricating oil(Engine)	Pan capacity	lit	Max : 40, Min : 33 (Engine total : 43)	
	Pressure	kg/cm ²	Full : 3.5, Idle : 1.2	
Direction of revolution	Crankshaft	Counter clockwise viewed from stern side		
Engine Size(L x W x H)	Without M/G	mm	1,973 x 1,233 x 1,606	
Engine dry weight	Without M/G	kg	1,750	1,830

H : Heavy Duty, M : Medium Duty, L : Light Duty

Engine Dimension

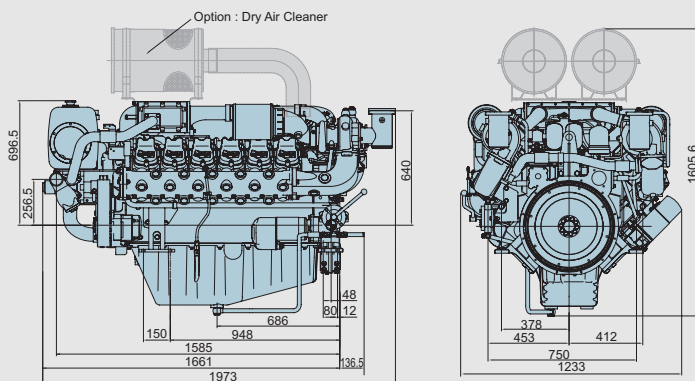

Performance Curve

- Heavy duty : 530kW(720PS)@1,800rpm
- Medium duty : 588kW(800PS)@2,100rpm
- Light duty : 736kW(1,000PS)@2,300rpm

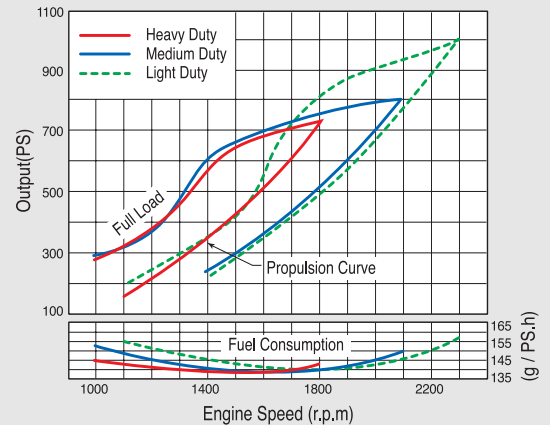

Marine rating to ISO 3046

(1) Heavy Duty

Operation hours are unlimited per year, at average load is up to 90 %, at full load is up to 80 %
Typical gearbox ratio: 2.5 ~ 6
(Fishing trawler, Tug boat, Pushing vessel, Cargo boat, Freighter, Ferry)

(2) Medium Duty

Operation hours are up to 3,000 per year, at average load is up to 70 %
At full load is (up to 30 % / 4hrs per 12 hour operation period)
Typical gearbox ratio: 2 ~ 3.5
(Fishing trawler, Pilot boat, Escort boat, Passenger boat, Freighter, Ferry, Cruising vessel)

(3) Light Duty

Operation hours are up to 1,000 per year, at average load is up to 50 %
At full load is (up to 20 % / 2hrs per 12 hour operation period)
Typical gearbox ratio: 1 ~ 2.5
(Light weight fishing boat, Yacht, Cruising vessel, Fast boat, Fire pump)

(Nov.2012)

AUTHORIZED DEALER

Doosan Infracore Engine

21/F, Doosan Tower, 18-12, Euljiro 6-ga,
Jung-gu, Seoul, 100-730, Korea.
Tel : 82 2 3398 8400
Fax : 82 2 3398 8509
Email : doosanmarine@doosan.com
http://engine.doosaninfracore.co.kr

* Specifications are subject to change without prior notice.