

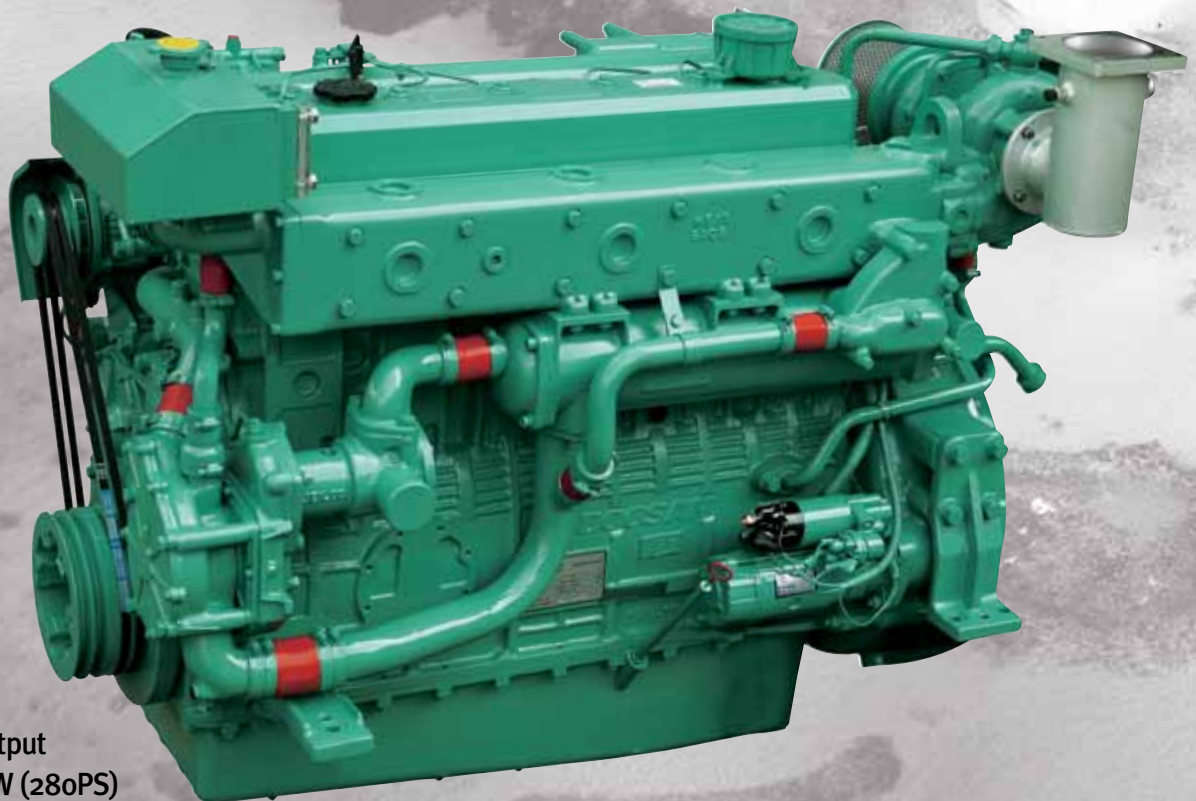

Marine Diesel Engine MD196T

- Compact Design
- Excellent Performance
- Low Fuel Consumption
- Easy Maintenance



- Rating output
 - 206kW (280PS)
- Displacement
 - 11,051cc
- Dimension (L × W × H)
 - 1,397 × 931 × 1,077mm
 - Without Reduction Gear

**Doosan Infracore
Engine**

Main Specification

Model	Units	MD196T
Engine type		4 cycle, In line, direct- injection, water cooled with turbo charger
Rating output	PS(kW)/rpm	280(206)/2,000
Displacement	cc	11,051
Cylinder number -bore x stroke	mm	6 - 123 x 155
Flywheel housing & fly wheel		SAE 1 & 14
Low idling rpm	rpm	725 ± 25
No load max. rpm	rpm	below 2,200
Compression ratio		17.1 : 1
Firing order		1 - 5 - 3 - 6 - 2 - 4
Governor type of injection pump		Mechanical variable speed (R.S.V)
Fuel consumption (only Ref.)@ rated power	g / ps.h	156
	Lit/h	49
Starting system		Electric Starting by starter motor
Starter motor capacity	V - kW	24 - 6.0
Alternator capacity	V - A	24 - 50
Battery	V - Ah	24 - 150
Cooling system		Indirect sea water cooling with heat exchanger
Cooling water capacity	Max. / Min.	lit 24 / 19
Fresh water pump type		Centrifugal type, driven by gear
Sea water pump type		Rubber impeller type driven by gear
Lubricating oil(Engine)	Pan capacity	lit Max : 25, Min : 19 (Engine total : 27)
	Pressure	kg/cm ² Full : 3.5, Idle : 1.2
Direction of revolution	Crankshaft	Counter clockwise viewed from stern side
Engine Size(L x W x H)	Without M/G	mm 1,397 x 931 x 1,077
Engine dry weight	Without M/G	kg 975

H : Heavy Duty, M : Medium Duty, L : Light Duty

Engine Dimension

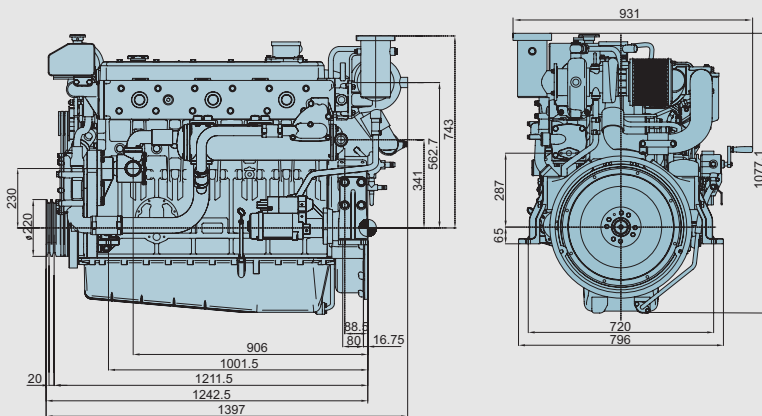

Performance Curve

• Heavy duty : 206kW(280PS)@2,000rpm

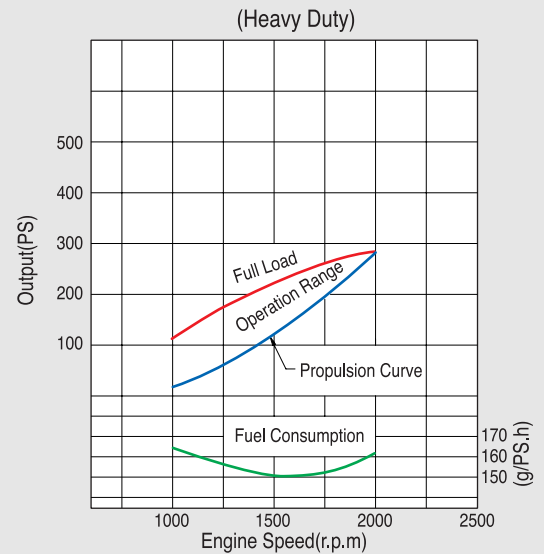

Marine rating to ISO 3046

(1) Heavy Duty

Operation hours are unlimited per year, at average load is up to 90 %, at full load is up to 80 %
 Typical gearbox ratio: 2.5 ~ 6
 (Fishing trawler, Tug boat, Pushing vessel, Cargo boat, Freighter, Ferry)

(2) Medium Duty

Operation hours are up to 3,000 per year, at average load is up to 70 %
 At full load is (up to 30 % / 4hrs per 12 hour operation period)
 Typical gearbox ratio: 2 ~ 3.5
 (Fishing trawler, Pilot boat, Escort boat, Passenger boat, Freighter, Ferry, Cruising vessel)

(3) Light Duty

Operation hours are up to 1,000 per year, at average load is up to 50 %
 At full load is (up to 20 % / 2hrs per 12 hour operation period)
 Typical gearbox ratio: 1 ~ 2.5
 (Light weight fishing boat, Yacht, Cruising vessel, Fast boat, Fire pump)

(Nov.2012)

Doosan Infracore Engine

21/F, Doosan Tower, 18-12, Euljiro 6-ga,
 Jung-gu, Seoul, 100-730, Korea.
 Tel : 82 2 3398 8400
 Fax : 82 2 3398 8509
 Email : doosanmarine@doosan.com
 http://engine.doosaninfracore.co.kr

AUTHORIZED DEALER

* Specifications are subject to change without prior notice.